

型号 Model: E2835UX128-18A

日期 Date: 2022-10-10

部门 Department: RD

版本 Edition: A/0

承认 Acceptance
 批量生产 Batch Production

 初步试样 Initial Sample

 客户专用设计 Customer Special Design

设计编号 Design Number:

	批准 Approval	审核 Audit	制作 Production
MLS			
客户会签 Customer Signature			
客户意见 Customer Comment			

地址: 广东省中山市小榄镇木林森大道 1 号

Address: No.1 Mulinsen Road, Xiaolan Town, Zhongshan City, Guangdong Province, China.

总机 (Switchboard): +86) 0760-8982 8888

E-mail: mls@zsmls.com

网站 (Website): http://www.zsmls.com

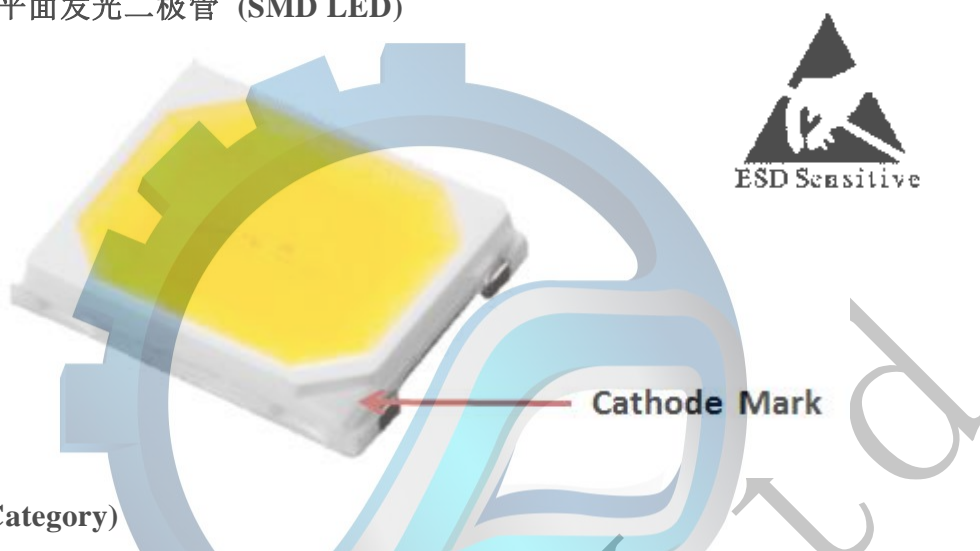
简述 (Description): 平面发光二极管 (SMD LED)

产品选择 (Product Category)

产品分类 LED Part Type	色温 CCT(K)	流明 Lumen(lm)			显指 CRI	测试电流 Current(mA)
		最小值 Min.	典型值 Typ.	最大值 Max.		
E2835UW128-18A	6500	120	125	130	70	20
E2835UN128-18A	4000	120	125	130		
E2835US128-18A	3000	115	120	125		
E2835UD128-18A	2700	115	120	125		

命名规则 (Product Nomenclature)

E 2835 U X 128 - 18A

E: 发光二极管 Emitting Diode

2835: 封装体型号 Package Model

X: 色温 CCT

D: 2700K S: 3000K N: 4000K Z: 5000K W: 6500K

128: 机种 Type

18A: 流水码 Water Number

封装尺寸 (Package Dimension)

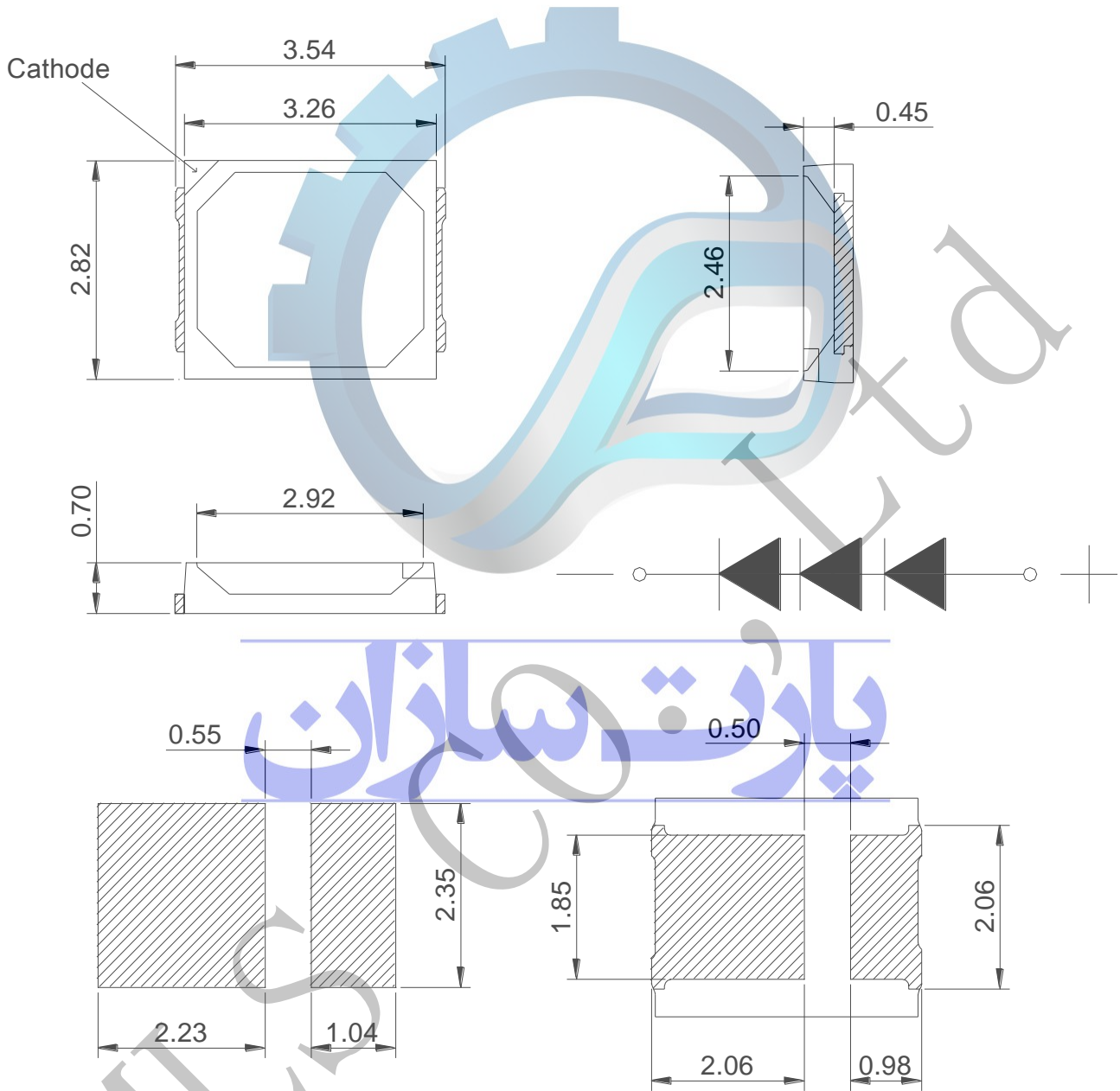

recommended bonding pad design

备注 (Remarks):

1. 所有尺寸单位为毫米

The units of all dimensions are in millimeters.

2. 未注明公差为 ± 0.1 毫米 (除非另有说明)

Dimension measurement tolerance is ± 0.1 mm (unless otherwise noted)

3. 规格若有变更恕不另行通知

Specifications are subject to change without prior notice.

最大参数值 (Maximum Absolute Rating, Ta=25 °C)

参数 (Parameters)	极限参数 (Maximum Value)	单位 (Unit)
功耗 (Power)	1000	mW
正向电流 (Max DC Forward Current)	20	mA
反向电压 (Reverse Voltage)	54	V

备注 (Remarks):

- 必须遵守适当的电流降额，以保持芯片结温始终低于最大值。
Proper current derating must be observed to maintain junction temperature below the maximum all the time.
- 发光二极管驱动电流不能以反向电流进行设计。
LEDs are not designed to be driven in reverse bias.

光电特性参数 (Optical Parameters, Ta=25 °C)

参数 Parameter	符号 Symbols	最小值 Min	标准值 Typical	最大值 Max	单位 Units	测试条件 Testing Conditions
发光角度 (Viewing Angle)	$2\theta_{1/2}$	--	120	--	Deg	IF=20mA
正向电压 (Forward Voltage)	V _F	51	-	55	V	IF=20mA
显色指数 (Color Rendering Index)	CRI	70	--	--	Ra	IF=20mA
ESD 测试 (ESD Testing)	E	90%	--	--	--	VR =2000V
结温 (Junction Temperature)	T _j	--	--	125	°C	IF=20mA
热阻 (Thermal Resistance) @25°C	R _{th}	--	25	--	°C/W	IF=20mA

备注 (Remarks):

- 此发光亮度根据人眼对发光亮度的感应曲线模拟发光强度，符合 CIE（国际光委会组织）。
This lighting luminance is based on the sensing curve of human eyes-to-luminance to simulate, which is in accordance with CIE (International Light Committee Organization).
- $2\theta_{1/2}$ 的角度是从光学中心线处的发光强度为 1/2 光学中心线值。
 $2\theta_{1/2}$ is the off-axis angle, where luminous intensity is 1/2 of the axial luminous intensity.
- 发光亮度保证误差 $\pm 4\%$ 。
Lumen tolerance is guaranteed within range of $\pm 4\%$.
- CRI x,y 测量误差 ± 0.003 。
Measurement tolerance of x, y is ± 0.003 .
- 测试结果为焊接直径为 20mm，厚度为 2mm 的 PCB 测试结果，所测数据为 MLS 的测试设备。
The tested result is based on LED mounted on the PCB. The PCB diameter is 20mm and thickness is 2mm. The optical measurement data is tested by MLS equipment.

典型的电性及视角曲线 (Typical Electrical and Perspective Curve)

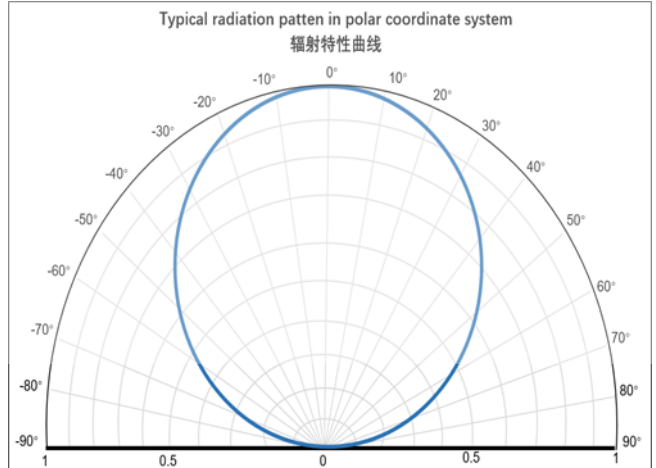
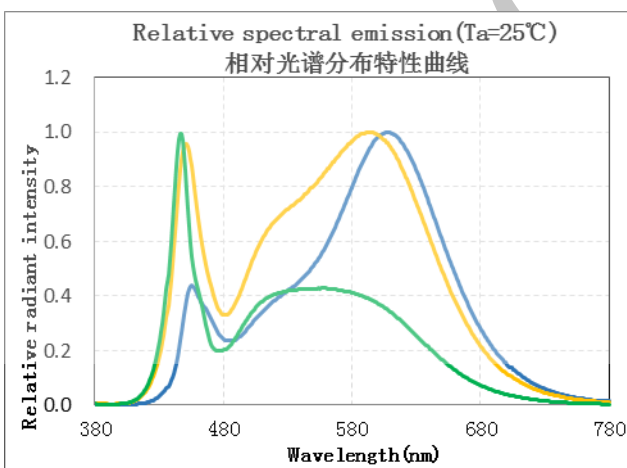
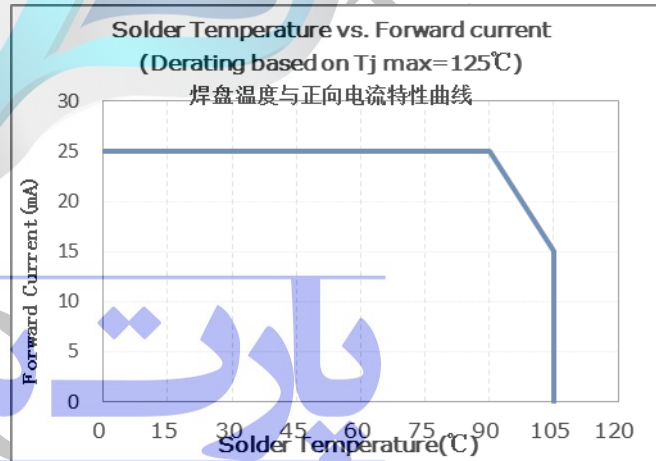
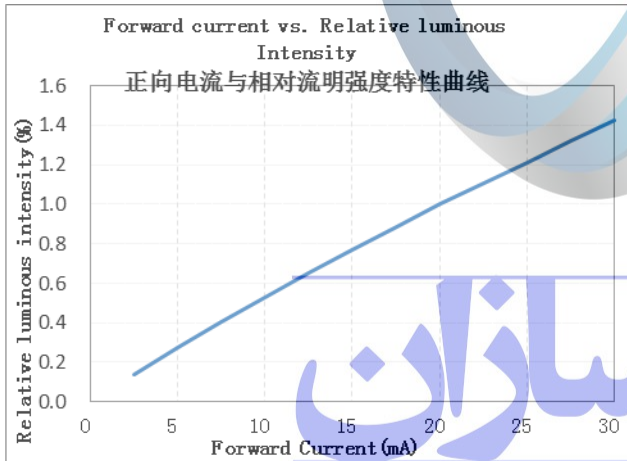
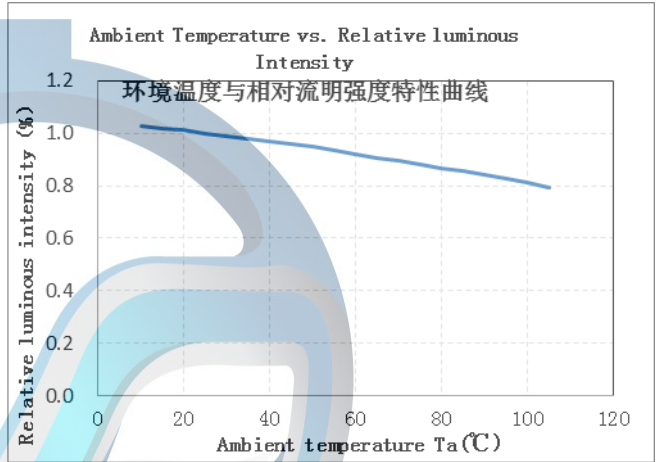
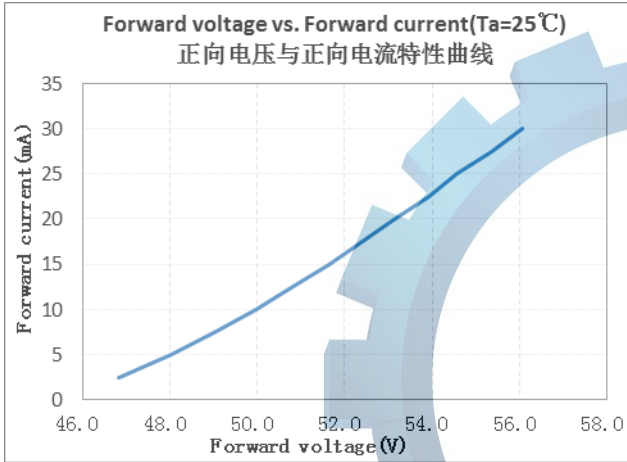

亮度 BIN 等级 (Lumen Bin Grade @ 20mA, Ta=25 °C)

参数 Parameter	符号 Symbols	等级 Grade	实际参数 Actual parameter	单位 Units
光通量 (Luminous Flux)	Φ	D120	115-120	Lm
		D125	120-125	Lm
		D130	125-130	Lm
		D135	130-135	Lm
		D140	135-140	Lm

电压 BIN 等级 (Vf Bin Grade @ 20mA, Ta=25 °C)

参数 Parameter	符号 Symbols	等级 Grade	单位 Units
电压 (Voltage)	VF	52-53	V
		53-54	V
		54-55	V

备注(Remarks):

- 需安装在金属基板上来保证良好散热
LED should be mounted on metal core PCB for good heat dissipation.
- VF 测试误差±0.1V
VF measurement tolerance is ±0.1V.
- 发光强度/光通量测试误差 ±4%
Tolerance measurement of luminous intensity / luminous flux ±4%.
- 色温保证误差 ±5%。
The tolerance of color temperature is ±5%.

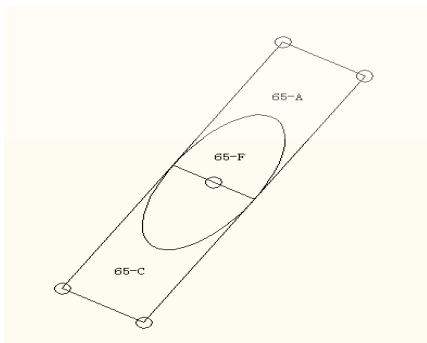
打靶图 (CIE Chromaticity Diagram)

65-F	CCT	Color Space	Center Xc	Center Yc	Major Axis	Minor Axis	Rotation Angle	Radians
	6500K	5 SDCM	0.318	0.342	0.01561	0.00665	58.57	
区域	①		②		③		④	
	X	Y	X	Y	X	Y	X	Y

65-C	0.3123	0.3455	0.3237	0.3385	0.3083	0.3134	0.297	0.3203
65-A	0.3277	0.3706	0.339	0.3637	0.3237	0.3385	0.3123	0.3455

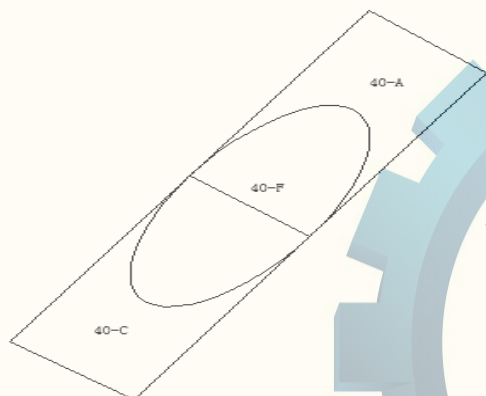

40-F	CCT	Color Space	Center Xc	Center Yc	Major Axis	Minor Axis	Rotation Angle	Radians
	4000K	5 SDCM	0.3851	0.3874	0.02191	0.00938	53.72	0.9376
区域	①		②		③		④	
	X	Y	X	Y	X	Y	X	Y
40-C	0.3775	0.3930	0.3926	0.3819	0.3706	0.3518	0.3551	0.3624
40-A	0.4000	0.4235	0.4147	0.4119	0.3926	0.3819	0.3775	0.3930

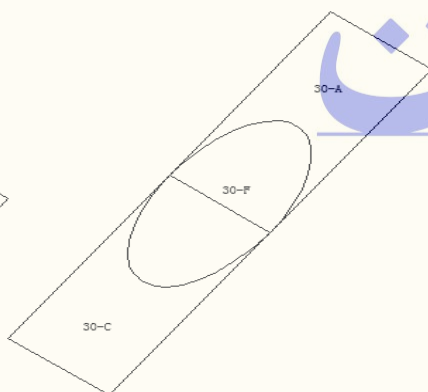

30-F	CCT	Color Space	Center Xc	Center Yc	Major Axis	Minor Axis	Rotation Angle	Radians
	3000K	5 SDCM	0.443	0.4109	0.01946	0.00952	53.22	0.9289
区域	①		②		③		④	
	X	Y	X	Y	X	Y	X	Y
30-C	0.4354	0.4166	0.4506	0.4052	0.4262	0.3726	0.4110	0.3840
30-A	0.4598	0.4492	0.4750	0.4378	0.4506	0.4052	0.4354	0.4166

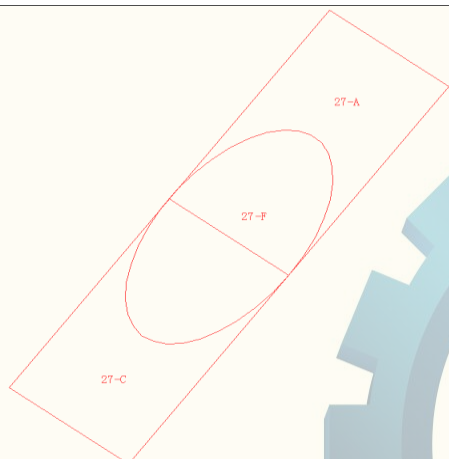

27-F	CCT	Color Space	Center Xc	Center Yc	Major Axis	Minor Axis	Rotation Angle	Radians
	2700K	5 SDCM	0.4644	0.4212	0.0236	0.01225	53.7	0.9372
区域	①		②		③		④	
	X	Y	X	Y	X	Y	X	Y
27-C	0.4545	0.4285	0.4743	0.4139	0.4479	0.3781	0.4282	0.3926
27-A	0.4809	0.4643	0.5006	0.4498	0.4743	0.4139	0.4545	0.4285

پارت سازان

MLS

可靠性测试项目及测试条件 (Reliability Test Items and Test Conditions)

编号 Number	测试项目 Test Item	实验条件 Test Conditions	样本大小 Sample Qty	判退/允收 Rejection/Acceptance
01	冷热冲击 Hot & Cold Thermal Shock	-40°C±5°C(15 mins) ~ 125°C±5°C(15 mins) 两温度转换时间(Transfer Time)<10 s 周期(Cycles): 200 个周期 (200 Cycles)	20PCS	0/20
02	高温寿命 High Temperature Operating Life	温度(Temperature): 105°C 电流(IF): 24mA 周期(Cycles): 1000H	20PCS	Failure: 0/20 ΔLumen: ≥80% Δu'v' : < 0.008
03	高温高湿 High Temperature & High Humidity Operating Life	温度(Temperature):85°C 湿度(Humidity):85% RH 电流(IF):24mA 周期(Cycles): 1000H	20PCS	Failure: 0/20 ΔLumen: ≥80% Δu'v' : < 0.008
04	组合测试 Combination Test	1) 85°C/85%RH 存储 8 小时 85°C/ 85% RH storage for 8 hours 2)焊接在 MPCB 板上过 3 次回流焊(最高温度 260°C) 3 Times reflow after LED mounted on the MC PCB(Max Temperature 260°C); 3)冷热冲击 100 个循环 100 Cycles Thermal Shock under below condition (-40°C/15min→中间转换(Transfer Time) 10s→125°C/15min)	20PCS	0/20

标签 (Label)

Model: 产品型号

Lot NO: 生产批号

IV: 发光强度等级

VF: 正向电压等级

X/Y(HUE): 发光颜色等级或者波长等级



Date Code: 生产日期/部门编号/机台编号/班次

Quantity: 数量

Remarks: 备注

Ra: 显值标准值

Model:	*****	
Lot No:	*****	Ra > **
IV:	*****	
VF:	*****	
X/Y(HUE):	*****	
Date Code:	****/**/****	
Quantity:	*****	PCS
Remarks:		



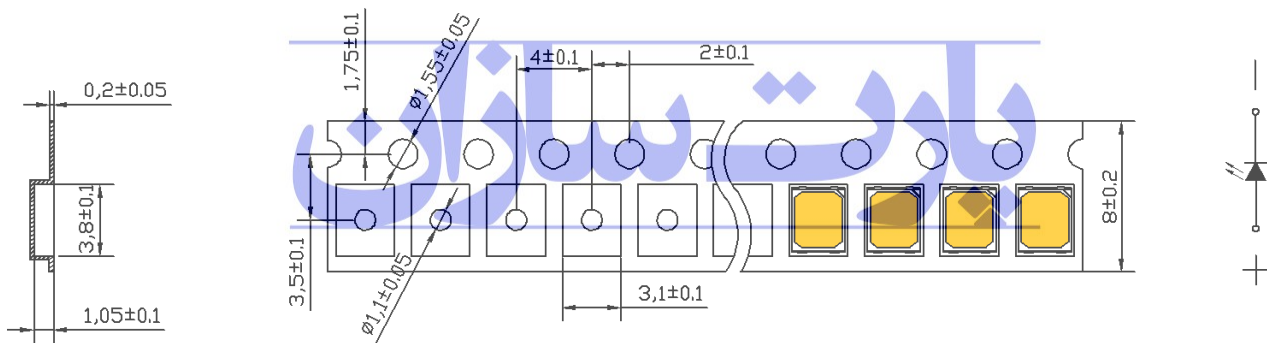

编带规格 Taping Specifications (单位 Unit: mm)

Feeding Direction 

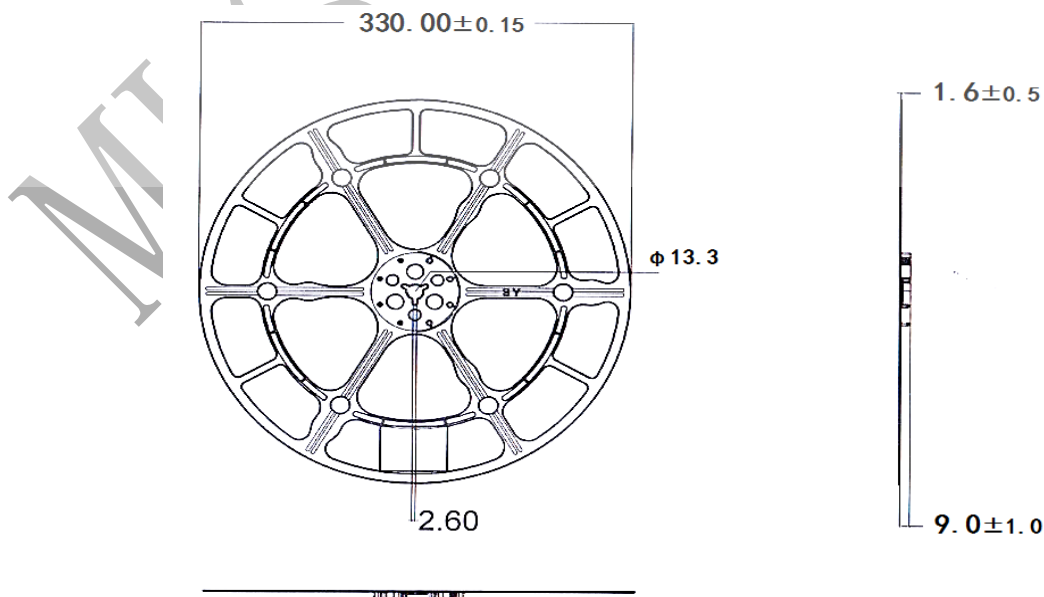

卷轴尺寸 Reel Size (单位 Unit: mm)



防潮包装 (Humidity Proof Packaging)

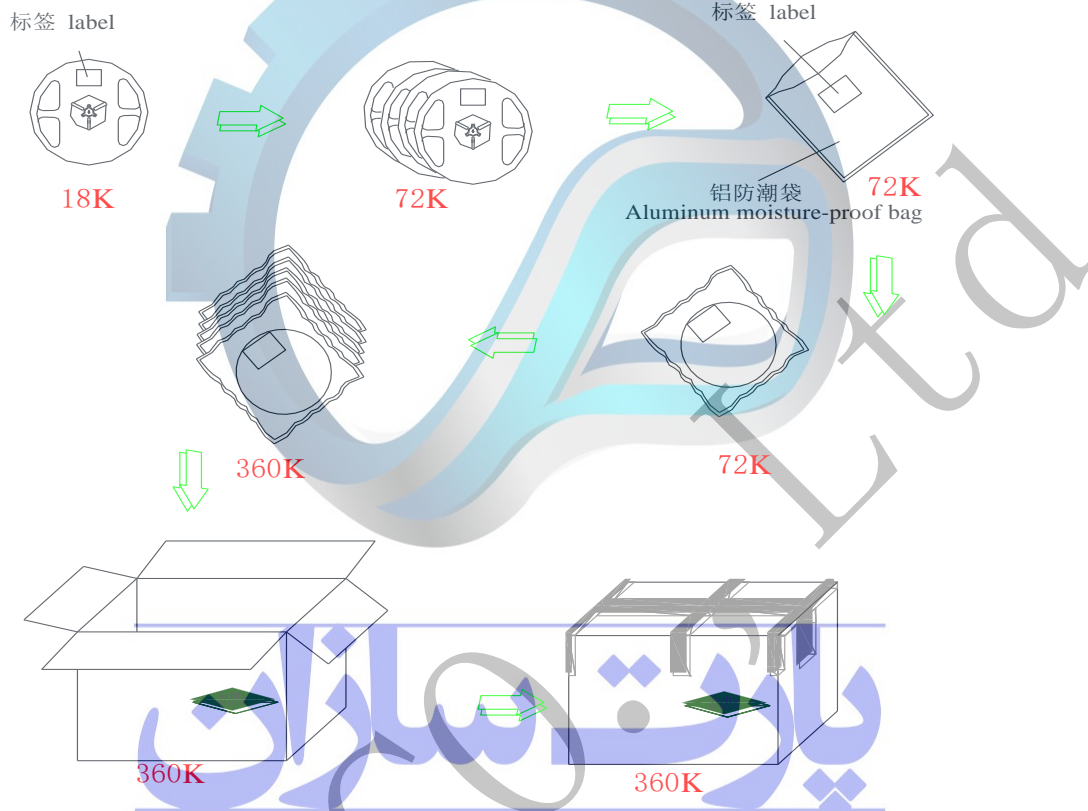

注意事项 (Notes)

封装发光二极管的材料是硅性质，因此发光二极管的表面柔软而有弹性。虽然有机硅的特点能降低热应力，但是更容易受到机械外力的破坏，在表面上施加压力将会影响发光二极管的可靠性。在这样的情况下，装配使用有机硅封装的发光二极管产品时必须遵守相应的处理措施，避免任何的施加给发光二极管的任何部分，所以在使用时请采用气动吸咀。否则会导致发光二极管损坏和可靠性降低影响其寿命。

Packaged LED material is silicone nature. Therefore, LED has a soft and flexible surface. Although characteristics of silicone can reduce thermal stress, but it is more susceptible to mechanical damage by the external forces applied on the surface. Pressure applied on the surface will influence the reliability of light emitting diodes. In such circumstances, when using organic silicon encapsulated LED products, customer must comply with the appropriate measures to deal with. To avoid any pressure applied to any part of the LED, please use pneumatic nozzle. Otherwise, it may lead products reliability and lifespan reduction of to the LED.

回流焊说明 (Reflow Soldering Instructions)

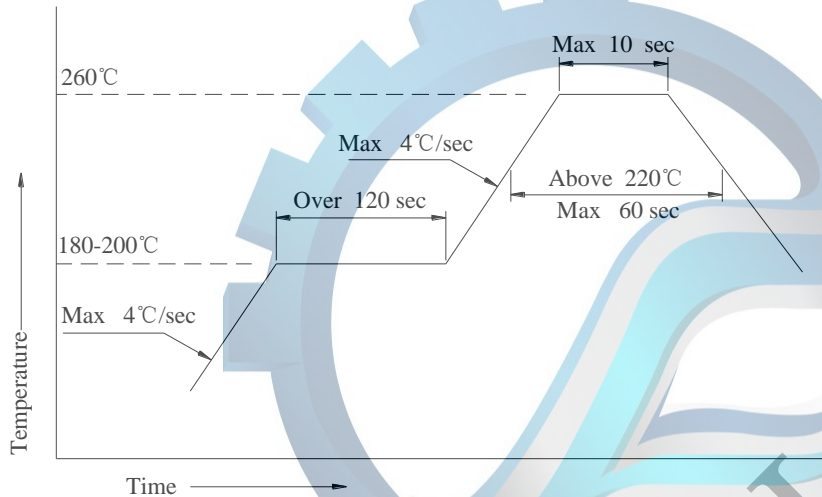

1、回流焊建议使用免清洗助焊剂，并依照回流焊曲线进行焊接，焊接次数不可超过 2 次。

Under reflow soldering, it is recommended to use no-clean flux, and solder operation according to the reflow curve. Maximum soldering *CAN NOT* exceed twice.

2、焊接时，不要在加热过程中对其施加压力。

When soldering, *DO NOT* exert pressure during heating process.

烙铁焊接 (Soldering Iron Welding Instructions)

1、当手动焊接时，建议采用 20W 的防静电烙铁，焊头的温度必须控制在 360°C 以下/3 秒，焊接次数为 1 次。

When under manual soldering operation, it is recommended to use 20W anti-electro static soldering iron, soldering temperature head must be kept below 360 °C / 3 seconds, soldering *CAN NOT* exceed once.

2、不可在同一单元板上焊接不同 BIN 的材料，否则会导致 LED 色差。

DO NOT mix different BIN materials on the same PCB, otherwise it will cause LED color variation.

修复 (Repairing)

当修复发光二极管时，应事先确认发光二极管是否会被破坏，修复过程中应避免接触胶体表面，双焊头烙铁应使用如下图的方式作业。

When repairing light-emitting diodes, it is advised to confirm the light emitting diode will be damaged, the repair process should avoid contact with the colloid surface, use of soldering iron should be according to following diagram.

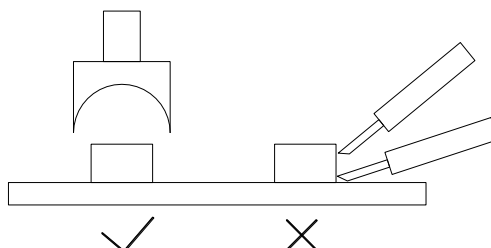

清洗 (Cleaning)

在焊接后推荐使用纯酒精清洗，清洗擦拭或浸渍不要超过 1 分钟。使用其它类似溶剂清洗前，请确保溶剂不会对发光二极管封装造成损伤。

It's recommended to use pure alcohol to clean after soldering. Cleaning, wiping or dipping *CAN NOT* exceed 1 minute. When other different solvents are used for cleaning, please make sure that solvents will *NOT* damage the light emitting diode material.

灌封 (Potting)

1、使用硅酮胶（玻璃胶）灌封时推荐采用中性、醇型类灌封胶。

When using silicone rubber (plastic glass) for potting, the neutral and alcohol-type potting glue are recommended.

2、灌封胶若使用脱肟型中性灌封胶，请确保灌封胶固化过程中的通风良好，在未完全固化过程中不可进行密封组装发光二极管元件。这样会造成镀银层氧化及发光颜色变淡。

When deoximation type neutral potting material is used, please make sure that the potting compound is well ventilated during curing process. *DO NOT* assemble light emitting diodes in sealed manner, before the potting is completely cured and or curing process is fully-completed. This will result in the situation of LED silver layer oxidation, luminous color fading, light degradation, or even failure of LED.

3、禁止使用醋酸型（酸性）硅酮胶进行灌封。

Prohibit to use acetic acid type (acidic) silicone rubber as potting materials.

4、使用正常灌封胶时建议进行少量灌封试验，常温点亮测试 168H 确认无异常后再批量作业。

It is recommended that small quantity samples for testing before batch potting. Before mass production, confirm that no abnormality phenomenon happens after lighting for 168 hours under $T_a=25^{\circ}\text{C}$.

5、更改任何一种灌封材料时，请先作试样确认是否对我司产品造成侵蚀反应。将灌封材料取 5-10g 和发光二极管 10-20pcs 于 100ml 的器皿内密封放置 168H 后确认产品是否有异常。

When changing any kind of potting material, please make samples to confirm whether there is erosion reaction. Take 5-10 grams of potting material and put 10-20 pcs LED samples in a 100ml sealed containers for 168 hours, to confirm whether there is abnormality.

驱动方式 (Driving Method)

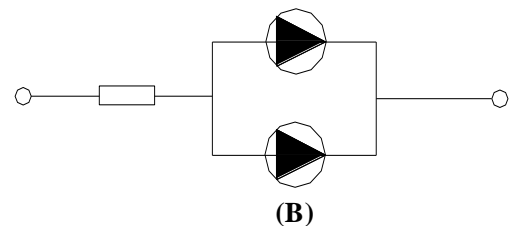
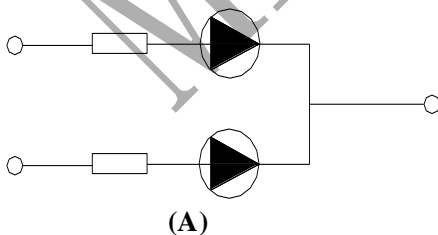

(A) 被推荐的电路 Recommended Circuits

(B) 每个灯珠可能出现亮度不一致，是由 I-V 的曲线而导致的

Each LED may appear inconsistent brightness, it is a result of the IV curve.

静电 (Static Electricity)

对于整个工序（生产、测试、包装等）所有与 LED 直接接触的员工都要做好防止和消除静电措施，主要有：

All employees who are in direct contact with the LED during all processes (production, testing, packaging, and etc.) must take measures to prevent and eliminate static electricity. Measurements as below:

1、 车间铺设防静电地板并做好接地，工作台采用防静电工作台，带电产品接触低阻值的金属表面时，由于急放电引发产品故障的可能性是很高的，故要求工作台及与产品相接触之处使用表面电阻为 $10^6-10^9\Omega$ 的桌垫。

The workshop needs to be equipped with anti-static flooring and make good ground connection. The work bench needs to adopt anti-static workbench. When a live product contacts a low-resistance metal surface, the probability of product failure due to a sudden discharge is high. Therefore, it is required to use a table mat with a surface resistance of $10^6-10^9\Omega$, when the workbench is in contact with the product.

2、 生产机台如：锡炉、回流焊、SMT 设备、电烙铁，以及检测设备均需接地良好，接地交流阻抗小于 1.0Ω 。在容易产生静电的环境与设备上，还必须安装离子风扇、作业过程中，操作员穿防静电服、带防静电手环、手套等，取放时尽可能接触产品的绝缘部分。

Production machines such as: tin furnace, reflow soldering, SMT equipment, electric soldering iron, and testing equipment need to be grounded, and grounded AC impedance should be less than 1.0 ohm. Prone to static electricity environment and equipment must be installed ion fan. During working process, operators need to wear anti-static clothing, wrist strap, gloves, and etc. When taking and or putting material, hold the insulated part of the product as much as possible.

3、 盛装 LED 使用防静电元件盒，包装则采用防静电材料。

Containing box and packaging materials for LED should be made of anti-static materials.

4、 请保持环境湿度在 60%RH 以下，以免空气过于干燥产生静电。

Keep ambient humidity below 60% RH to avoid air being too dry to generate static electricity.

5、 静电接地需与电源零线、防雷地线分开，接地措施应完全防止静电产生，必须用粗的铜线引入泥土内，在铜线末端系上大铁块，埋入地表 1 米以下，各接地线均需与主线连接在一起。

Grounding should be connected to the neutral input line. It should be separated from the lightning grounding. Grounding should be done with anti-static. Heavy gauge copper cable should be connected to a large piece of metal and buried at least 1 meter deep into the ground. All ground cables must be connected together with the main cable.

使用操作示意图 (Operating Diagram)

1、 使用镊子或合适的工具，沿侧表面夹取元件。

Use forceps or other appropriate tools grip along the side surface of component.

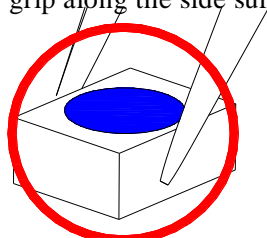

2、不要接触有机硅的表面，它可能会破坏发光二极管的内部电路。

DO NOT touch the silicone surface. It may damage the internal circuit of the LED.



3、不要将焊接好的发光二极管堆叠放置，会导致发光二极管划伤及胶体受损造成死灯。

DO NOT stack soldered LED, it may cause scratching of LED and silicone damage and leading to dead LED.

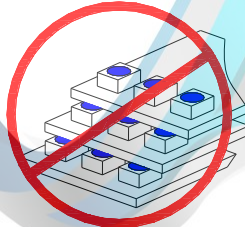

4、不可接触和使用天那水、三氯乙烯、丙酮、硫化物、钠离子及酸、碱、盐等物质，这样会造成镀银层氧化及荧光粉硫化。致使发光二极管发光颜色变淡、亮度变暗等现象发生。

DO NOT make contact with Thinner, Trichloroethylene, Acetone, Sulfide, Sodium Ion and Acid, Alkali, Salt and other substances. These materials will cause LED silver-plated layer oxidation and vulcanization of phosphor, which will lead LED color fading and brightness reduction conditions to happen then.



储存 (Storage)

1、建议未拆封前储存条件：小于 30°C/60%RH 下，保存期限为一年。

Recommended storage conditions before opening packaging: Ta<30°C/<60% RH. Retention period: 1 year.

2、拆封后在室温<30°C，湿度 60%RH 以下，建议在 4H 内完成回流焊作业，12H 内完成封装作业。因发光二极管吸湿后回流焊高温会导致硅胶与 PCT 分层，元器件失效。对于未使用之产品，请采取除湿处理（卷轴产品 75°C ±5°C/12H，散装产品 110°C ±5°C/1H，在烤箱内作自然冷却 1H）后再进行使用。

After unpacking: Ta<30 °C, Humidity <60% RH, it is recommended to complete the reflow soldering operations within 4 hours; to complete LED luminaries within 12 hours. If LED absorbed moisture before high temperature reflow soldering, it will cause silicone and PCT to separate, and lead components failure. For unused products, please adopt dehumidification procedure (Reel products heating 75 °C ± 5 °C / 12H; Bulk products, heating 110 °C ± 5 °C / 1H, then natural cooling in the oven for 1H) before reuse.

3、使用时若发现有包装袋真空失效时，请不要使用，需要进行除湿后才可使用。

If you find that the bag has a vacuum failure before usage, please stop to use it. Dehumidifying is needed before reuse.

4、潮湿等级：3级（暴露于小于或等于 30 °C/60% RH 车间，168H 寿命）。

Moisture Rating: Class 3 (Exposure under $T_a \leq 30^\circ\text{C}$ / 60% RH workshop, 168H life)

硫化实验 (Vulcanization Resistance Test)

实验示意图如下图所示：

The schematic diagram of the experiment shown as below:

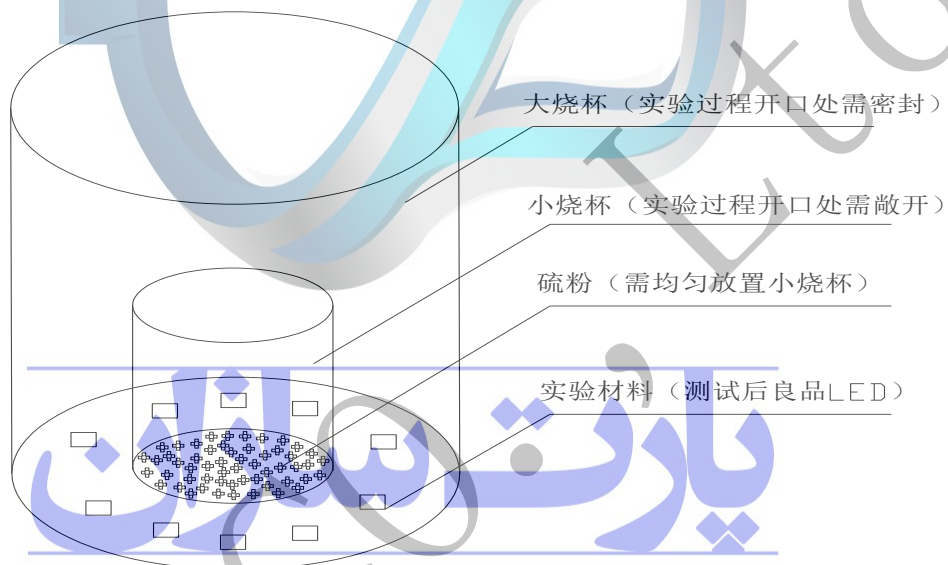

将 1g 硫粉均放于小烧杯底部，然后将小烧杯正置大烧杯中间。大小烧杯空隙间均匀放入 10 个 LED 灯珠并密封大烧杯后放置 80°C 烤箱烤 4 小时。

Put 1g sulphur powder into the bottom of small beaker, then put the small beaker in the middle of a big beaker. Between the small and big beaker, evenly put 10 pcs LED samples, seal the big beaker, and then put into oven for 4 hours under 80°C condition heating.

判定标准：硫化 4H 后光通量维持率需 $\geq 80\%$ ，即最大允许衰减 20%。

Judgment Criteria: After 4 hours vulcanization testing under above condition, the luminous flux maintenance rate needs to be $\geq 80\%$, that is, the maximum acceptable lumen depreciation is 20%.